



VIPer50 DEMOBOARD EMI APPLICATION

Ed Wenzel

1. ABSTRACT

This general flyback circuit can be used to produce any output voltage in primary or secondary mode regulation and is suitable for any multiple output voltage power supply. The VIPer50 Demo Board is designed for one 18V at 1.4A output voltage and will run from 85 to 264VAC. It contains an axial output rectifier BYW98-200 and uses only one of the available output capacitors at C10 (see figure 1). It also contains some of the components that may be required for EMI and can be used for EMI testing with the additional component space provided.

2. INTRODUCTION.

The VIPer50 technology contains a state of the art PWM circuit and a Vertical Power MOSFET, which is avalanche rugged, on the same silicon chip. It is suitable for off line wide range input voltage flyback power supplies of up to 25W (50W for high input voltage range) in discontinuous mode. This solution has the advantage of using few external components compared to a discrete solution, can be used for primary or secondary regulation, has a burst mode in standby for Blue Angel operation, an external pin is used to set the operating frequency up to 200kHz, an external pin is provided for compensation, has current mode control, a built in current limit and contains thermal protection.

Table 1: Operating Conditions

Parameter	Limits
Input Voltage Range	85 to 246VAC
Input Frequency Range	50/60Hz
Temperature Range	10 to 55°C
Output Voltage	18V (sec.), 21V (pri.)
Output Power (discontinuous)	25W
Output Power (peak)	34W
Line Regulation	See Line Regulation
Load Regulation	See Load Regulation
Efficiency	See Figure 6
Output Ripple Voltage	0.1V p-p (18V, C10 only)

The circuit in figure 1 contains an F1 input fuse, an R1 inrush thermistor, C1, C14, C17, C18, C19, L1, L2, L3, L5 EMI filtering. A C4 and R3 input fuse and a C3, D1, R2 clamp circuit. C7, C8 and R6 are used for compensation, R5 and C6 are used to set the operating frequency, C15 and R8 provide extra immunity for lightning strike. Positions for output capacitors C9, C10, C11 are provided as well as an output filtering inductor L4. A TL431 U3 is used with an optoisolator U2 for secondary regulation.

The schematic contains most of the components which can be assembled on the PCB but all of the com-

ponents are not necessary present at one time. Each application is different and will require a particular component set to meet EMI and output ripple voltage depending, for example, on the PCB layout and the leakage inductance of the output transformer.

Figure 1: Application Circuit

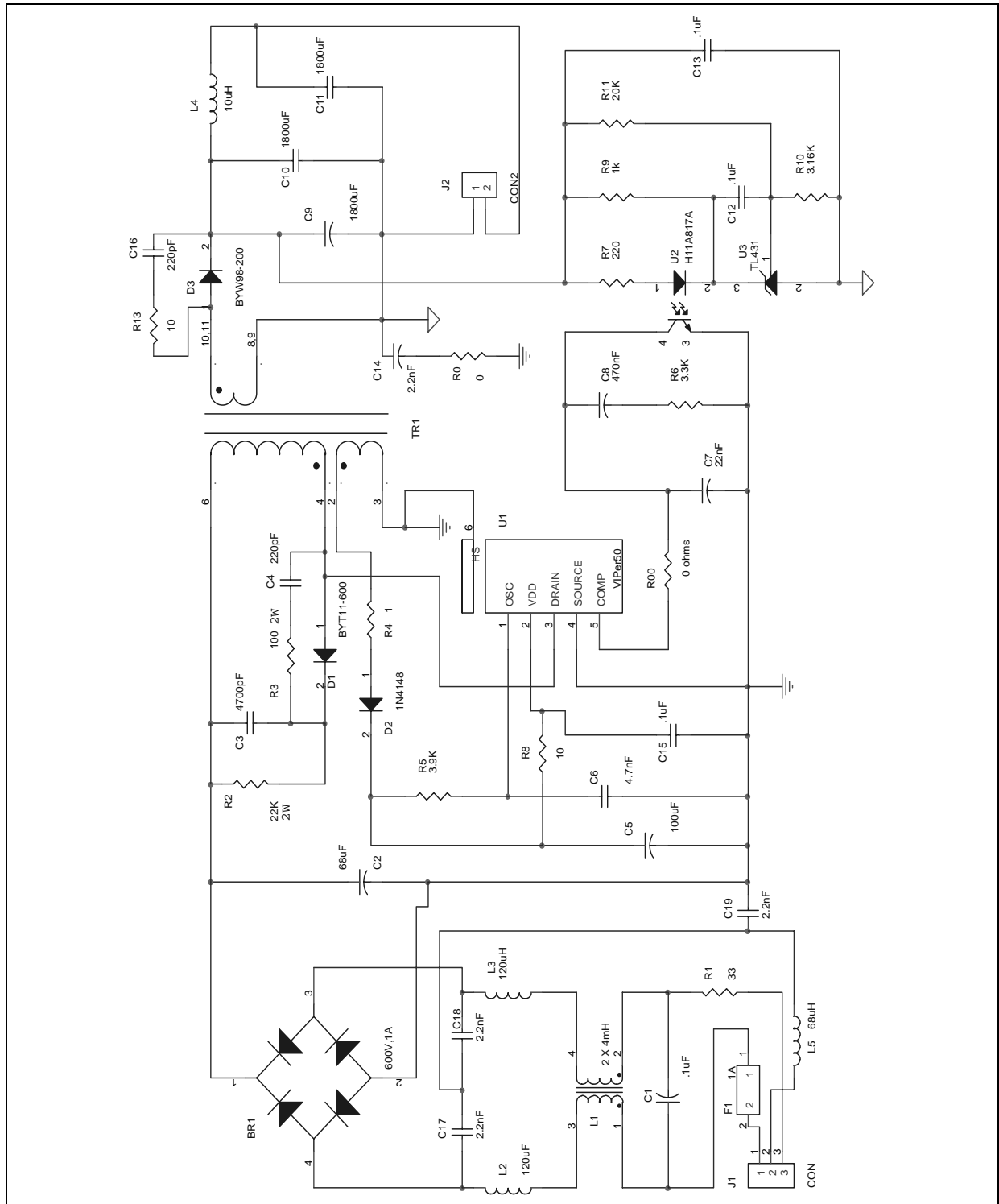

Table 2: Components Listing

Reference	Value	Part Number	Manufacturer
BR1	600V, 1A		
C1	0.1 μ F, 250V		
C2	68 μ F, 400V		
C3	4700pF, 1kV		
C4, C16	220pF, 1kV		
C5	100 μ F, 25V		
C6	4.7nF, 50V		
C7	22nF, 50V		
C8	470nF, 50V		
C9, C10, C11	1800 μ F, 25V		
C12, C13, C15	0.1 μ F, 50V		
C14, C17, C18, C19	2.2nF, "Y", 250V		
D1		BYT11-600	STMicroelectronics
D2		1N4148	
D3		BYW98-200	STMicroelectronics
F1	1A, 5X20mm		
J1	5mm	CON	Phoenix
J2	5mm	CON	Phoenix
L1	2X4mH	RN114-2/02	Schaffner
L2, L3	120 μ H		
L4	10 μ H		
L5	68 μ H		
R0, R00	0 Ω		
R1	33 Ω	CL210	NTC
R2	22K Ω , 2W, 5%		
R3	100 Ω , 2W, 5%		
R4	1 Ω , 0.25W, 5%		
R5	3.9K Ω , 0.25W, 5%		
R6	3.3K Ω , 0.25W, 5%		
R7	220 Ω , 0.25W, 5%		
R8, R13	10 Ω , 0.25W, 5%		
R9	1K Ω , 0.25W, 5%		
R10	3.16K Ω , 0.25W, 5%		
R11	20K Ω , 0.25W, 5%		
TR1		CVP 45-001	Cramer Coil & Transf.
U1	575002T00000	VIPer50 (022Y) Heatsink AA VID	STMicroelectronics & In- sul. mount. kit
U2		H11A817A	
U3		TL431	STMicroelectronics

3. WAVE FORMS.

Figures 2 and 3 show typical turn off wave forms of the drain source voltage, drain current and drain source voltage times drain current for an input voltage of 115VAC and 260VAC respectively at maximum load current.

Figure 2: Drain Source Voltage and Drain Current

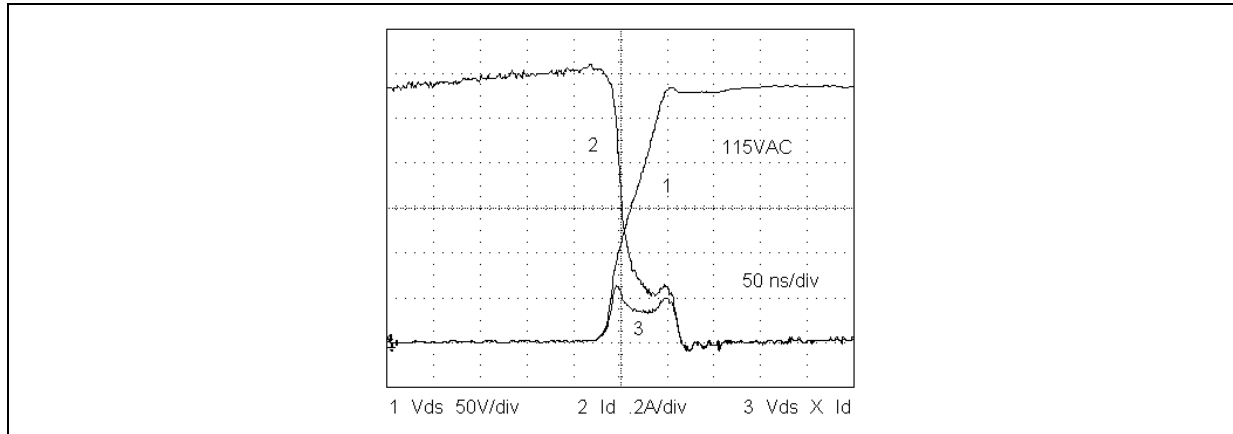
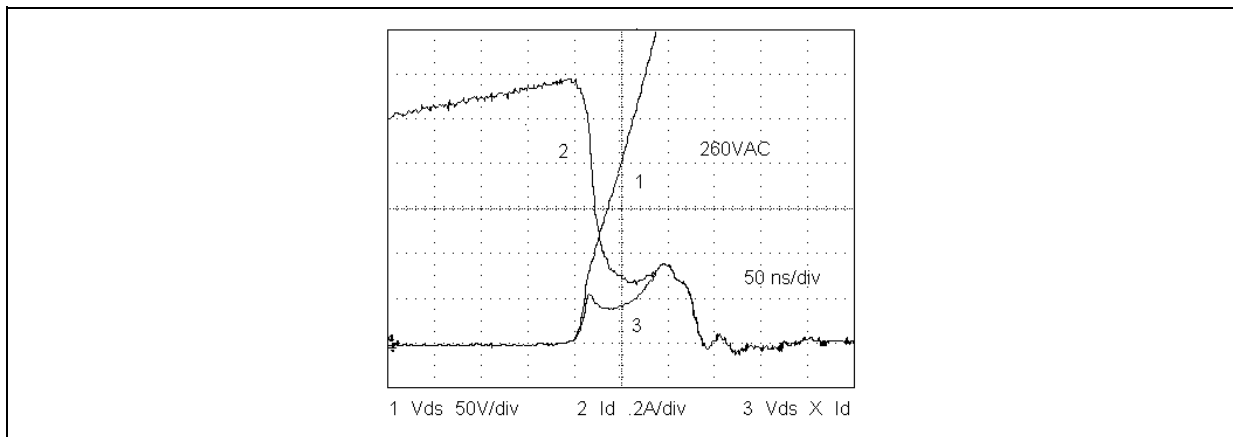

Figure 3: Drain Source Voltage and Drain Current



4. BOARD LEGEND.

As you can see in figures 4 and 5, the printed circuit board (PCB) layout takes in consideration various components that can be used for different applications. There are various patterns of holes for the output transformer to accommodate different bobbins that may be used. In the output section, an axial lead or a TO-220 diode mounted to a heat sink can be used for outputs with higher output current. Also, there are mounting holes for extra output capacitors and an output choke for additional filtering. Holes are provided for additional components that may be needed to meet various EMI requirements: The AC input connector has positions for line, neutral and a ground connection and the PCB has a position for an inductor in the ground leg. Holes are provided for line to ground capacitors (Y - caps) on both sides of the line to ground, to bulk return and to the secondary return. There is a resistor capacitor snubber for the Viper50 (R3, C4). There is also a resistor capacitor snubber (R13, C16) for the output rectifier (D3). A resistor capacitor diode clamp circuit (R2, C3, D1) can be used or there are holes provided for a transil. Holes are provided for differential mode inductors - one in each leg. A low profile common mode choke can be used with one line to line capacitor or a stand up common mode choke can be used with two line

to line capacitors, one on each side. The following components, some of which are used for EMI and others are used for additional output current and filtering on the output voltage, are not mounted on the demo PCB: C9, C11, C13, C16, C17, C18, C19, L4, L5, R13.

Figure 4 shows the VIPer50 Demo Board Legend. The components for the major loop (the bulk capacitor C2, the primary on the output transformer TR1 and the VIPer50 U1) are placed in close proximity so that the current loop area is as small as possible. Also, components on the secondary (output rectifier D3, capacitors C9, C10, C11, and transformer output winding 10,11-8,9 (TR1) are placed to reduce the current loop area. Figure 5 shows the VIPer50 Demo Board printed circuit Board layout. Note that the width of current loop area used is as small as possible and still meet the voltage spacing requirements.

Figure 4: PC Board Top Legend

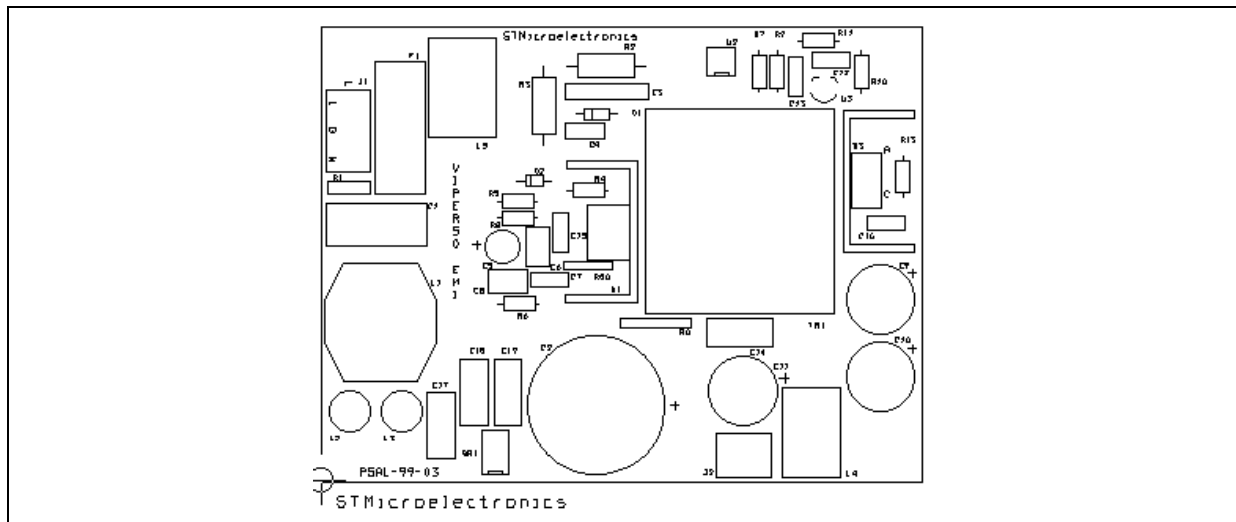
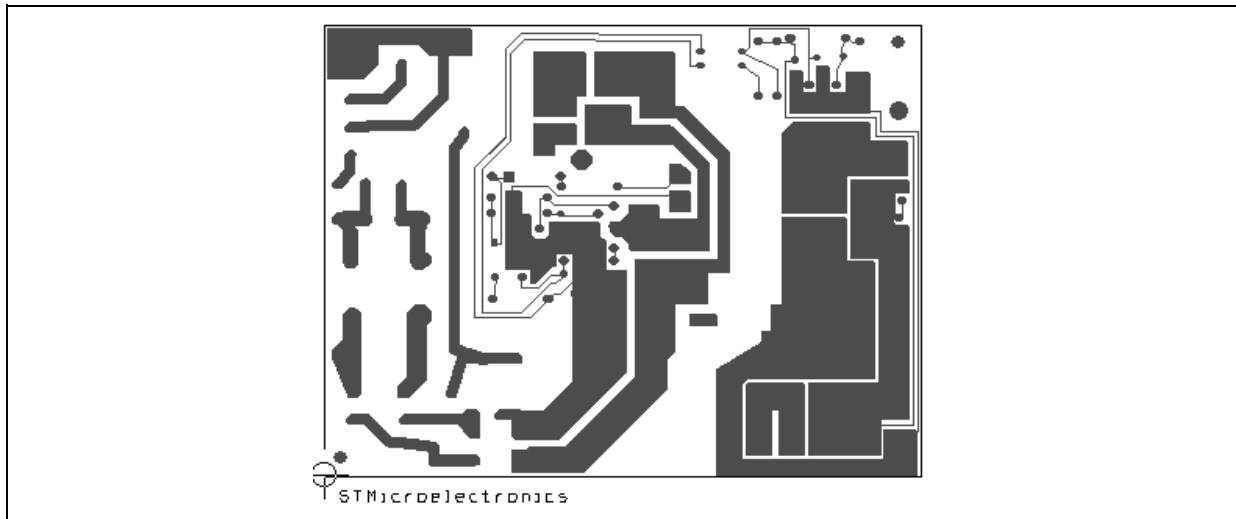

Figure 5: PC Board Top Foil



5. EFFICIENCY VS. OUTPUT POWER.

A graph of efficiency vs output power for 115 and 230VAC is found in Figure 6. An efficiency of 70% can be expected for an output load of 25% of full load and an efficiency of 80% can be realized for operation at full load.

Figure 6: Efficiency vs. Output Power

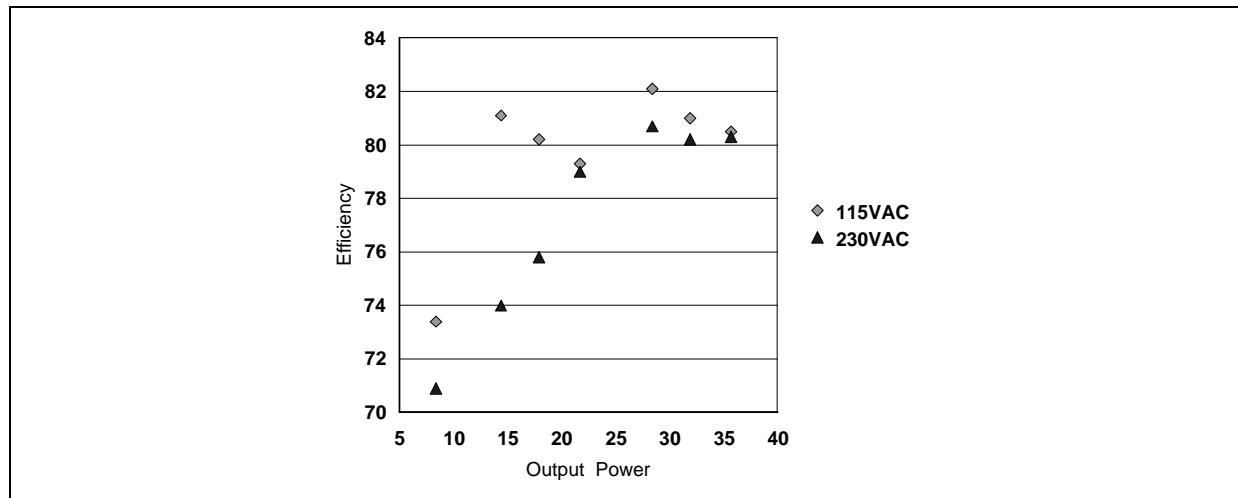

6. GENERAL CIRCUIT DESCRIPTION.

The VIPer50 Demo Board is designed as a discontinuous flyback regulator where the energy is stored in the transformer TR1, with primary winding 4-6, when the VIPer50 (U1) is on and delivered to the output, 10,11-8,9, and auxiliary winding, 2-3, when the VIPer is off. The auxiliary winding provides the bias voltage for the VIPer at the Vdd pin 2. The frequency of operation is determined externally by R5 and C6 at osc. pin 1. The output voltage is regulated with the shunt regulator U3. The U3 input voltage, before the output inductor L4, is regulated via the optoisolator, U2, through R7. The components R6, C7 and C8 are used for compensation.

7. THERMAL CONSIDERATIONS.

The demo board is single sided and utilizes one ounce copper for all of the traces. A heatsink is used on the demo board, for the VIPer50, which is connected (soldered) to the primary return. This will help reduce EMI and requires an insulation mounting kit to separate the VIPer50 drain from the heatsink. The demo board can be used for 25W for a wide input range and the VIPer50 can reach a peak Ids current of 1.5A before a thermal limit. The output diode, D3, can be used for 18V at 1.4A.

8. TRANSFORMER CONSIDERATIONS.

The output transformer has a primary inductance of 330uH, a ferrite core EE30/15/07 with an AL of 215 and is primary - secondary Hi Pot tested to 4000VAC for 1 second. It is wound with the primary first, the secondary wound next and the auxiliary winding last. The VIPer50 EMI Demo Board assembly now contains an output transformer, built by Cramer Coil & Transformer Co., Inc. (CVP 45-001), which produces 18V at 1.4A for an input voltage of 85 to 260VAC. For this low current output, only one output capacitor (C10) is used and C9, C10 and L4 are not needed to lower the output ripple voltage.

9. PERFORMANCE CONSIDERATIONS.

In order to obtain the same power with a lower voltage and more current a TO-220 heatsink is provided for D3. Higher output current may require more of the output capacitors and the output inductor depending on the current rating of the capacitors and the required output ripple voltage. For better regulation, the tolerance of the U2 reference ($\pm 5\%$ to $\pm 2.2\%$) and the tolerance of resistors R10 and R11 can be improved.

10. COST CONSIDERATIONS.

Primary mode regulation can be used without U2, U3, C12, C13, R7, R9, R10, and R11 for a greater than 5% regulation requirement. Not all of the EMI components will be required depending on the application.

11. LINE REGULATION.

For secondary regulation, the regulation due to line is of secondary importance compared to the regulation due to U3. With a 3:1 line variation, the 18V output voltage variation measured was less than 0.01%. For primary regulation, regulation for a 3:1 line variation is less than 0.4%.

12. LOAD REGULATION.

For secondary regulation, the regulation due to load is of secondary importance compared to the regulation due to U3. If output inductor L4 is used, the output voltage variation due to a change in load current should also be considered. With a 10:1 load variation, the 18V output voltage variation was less than 0.1%. For primary regulation, regulation for a 10:1 load variation is less than 6.0%.

Information furnished is believed to be accurate and reliable. However, STMicroelectronics assumes no responsibility for the consequences of use of such information nor for any infringement of patents or other rights of third parties which may result from its use. No license is granted by implication or otherwise under any patent or patent rights of STMicroelectronics. Specification mentioned in this publication are subject to change without notice. This publication supersedes and replaces all information previously supplied. STMicroelectronics products are not authorized for use as critical components in life support devices or systems without express written approval of STMicroelectronics.

The ST logo is a trademark of STMicroelectronics

© 2000 STMicroelectronics - Printed in Italy - All rights reserved

STMicroelectronics GROUP OF COMPANIES

Australia - Brazil - China - Finland - France - Germany - Hong Kong - India - Italy - Japan - Malaysia - Malta - Morocco - Singapore - Spain - Sweden - Switzerland - United Kingdom - U.S.A.

<http://www.st.com>